

图片型号 PICTURE MODEL:DR-70/DFR-230

Marine Cabin Refrigerator 船用舱室冰箱

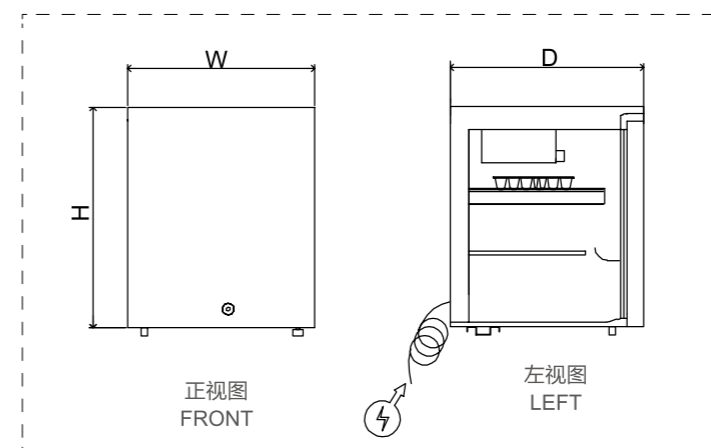

- ◆ 表面采用烤瓷处理
Enameled surface
- ◆ 容量 50L—330L 可供选择并带锁
The capacity is variable between 50L to 330L and lock is available
- ◆ 采用高性能压缩机及环保型制冷剂 R134a
Compressor with good quality and environment-friendly refrigerant R134 are used
- ◆ 采用环戊烷碳氢无氟微孔发泡，保温性能好
Cyclopentane fluorine free hydrocarbon microcellular foaming is used for good thermal insulation
- ◆ 可选配船用落地可调节底脚及固定支架
Marine adjustable legs and rear fasteners are optional

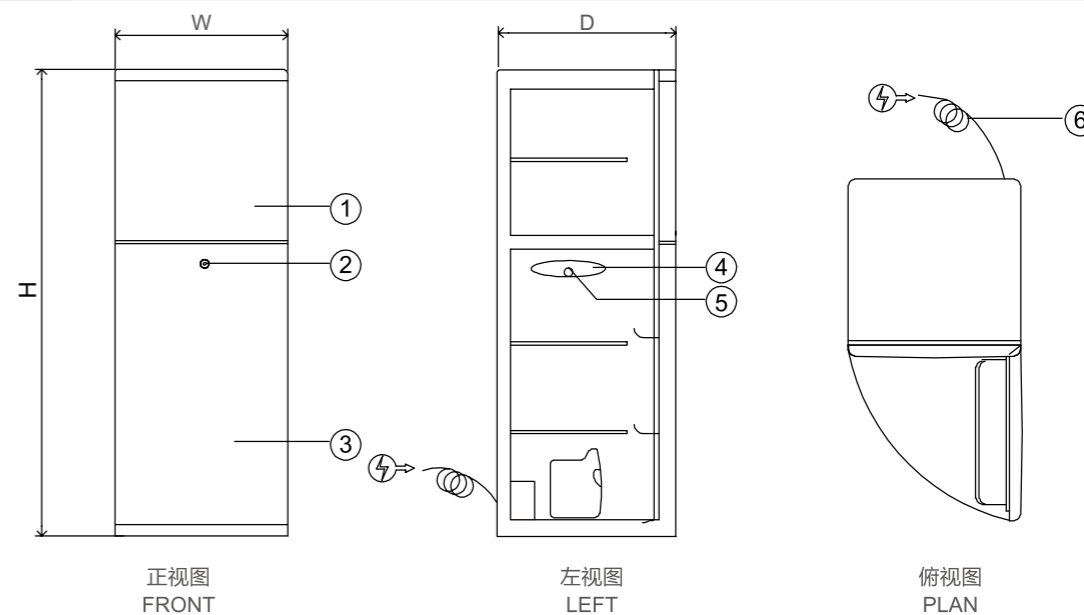

- ① 冷冻室
Freezing Chamber
- ② 门锁
Locker
- ③ 冷藏室
Refrigerating Chamber
- ④ 温控器
Temp Controller
- ⑤ 照明灯
Chamber Light
- ⑥ 电源线
Electric Cord

设备名称 Equipment	型号 Model	容量 Capacity	功率 Rating	电制 Voltage	尺寸 Size (W×D×H)	重量 Net Weight
船用舱室冰箱 (单门) Marine Cabin Refrigerator (Single-Door)	DR-50	50L	0.08kW	220V/1/50Hz 230V/1/60Hz	480×450×487mm	16kg
船用舱室冰箱 (单门) Marine Cabin Refrigerator (Single-Door)	DR-70	70L	0.09kW	220V/1/50Hz 230V/1/60Hz	475×445×625mm	17kg
船用舱室冰箱 (单门) Marine Cabin Refrigerator (Single-Door)	DR-90	90L	0.1kW	220V/1/50Hz 230V/1/60Hz	470×440×835mm	20kg
船用舱室冰箱 (单门) Marine Cabin Refrigerator (Single-Door)	DR-120	120L	0.11kW	220V/1/50Hz 230V/1/60Hz	510×550×805mm	32kg
船用舱室冰箱 (双门) Marine Cabin Refrigerator (Double-Door)	DFR-140	140L	0.13kW	220V/1/50Hz 230V/1/60Hz	460×525×1305mm	32kg
船用舱室冰箱 (双门) Marine Cabin Refrigerator (Double-Door)	DFR-180	180L	0.14kW	220V/1/50Hz 230V/1/60Hz	550×560×1250mm	35kg
船用舱室冰箱 (双门) Marine Cabin Refrigerator (Double-Door)	DFR-230	230L	0.15kW	220V/1/50Hz 230V/1/60Hz	550×570×1410mm	41kg
船用舱室冰箱 (双门) Marine Cabin Refrigerator (Double-Door)	DFR-330	330L	0.25kW	220V/1/50Hz 230V/1/60Hz	600×580×1890mm	52kg