

图片型号 PICTURE MODEL: BSG80

Marine Soup Boiling Pan 船用固定式汤锅

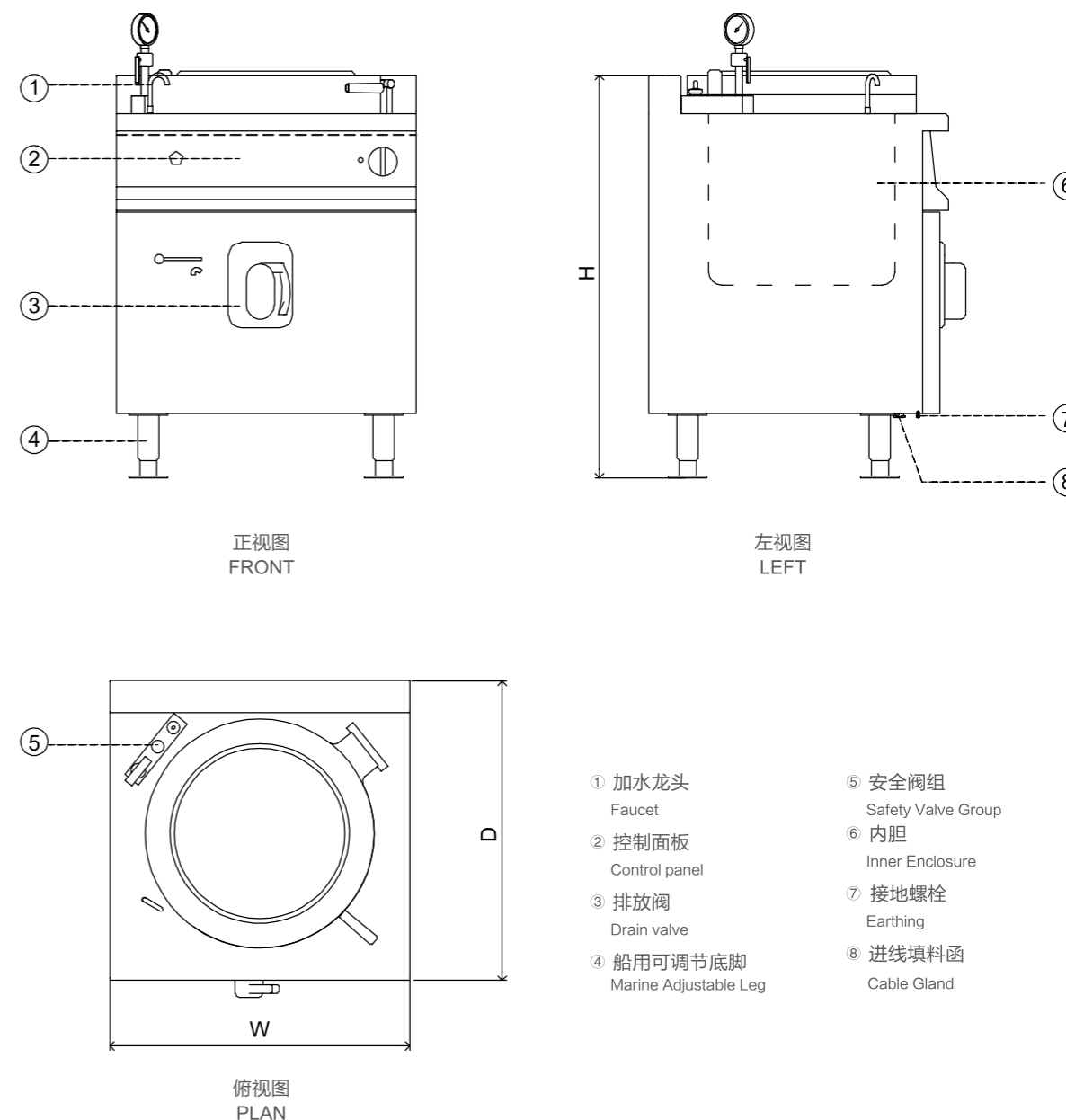

- ◆ 全不锈钢结构
S/S execution
- ◆ 锅体采用三层结构，间接加热，加热高效均匀
The pan body is designed with three insulation tiers ,
The heating is indirect, efficient and even
- ◆ 带有低水位自动断电保护功能
Automatic water lacking breaker protecting function
- ◆ 外置压力表、减压阀，对设备进行过压保护
External pressure gauge and pressure releasing valve
are applied for overpressure protection
- ◆ 外隔层间填充高复合隔热材料，确保热量不外导
The outer insulation tier is made of compound insulation material
and can prevent heat from radiating
- ◆ 带防风浪锅盖
Anti-storm pan lid is provided
- ◆ 两种加热方式：电加热、蒸汽加热
Two kinds of heating types: single electric heating type, single steam
heating type



设备名称 Equipment	型号 Model	容量 Capacity	功率 Rating	电制 Voltage	尺寸 Size (W×D×H)	重量 Net Weight
船用固定式汤锅 Marine Soup Boiling Pan	BSG40	40L	9kW	380-415V/3/50Hz 440-480V/3/60Hz	700x700x850	65kg
船用固定式汤锅 Marine Soup Boiling Pan	BSG60	60L	9kW	380-415V/3/50Hz 440-480V/3/60Hz	800x900x850	100kg
船用固定式汤锅 Marine Soup Boiling Pan	BSG80	80L	12kW	380-415V/3/50Hz 440-480V/3/60Hz	800x900x850	120kg
船用固定式汤锅 Marine Soup Boiling Pan	BSG100	100L	15kW	380-415V/3/50Hz 440-480V/3/60Hz	800x900x850	150kg