

图片型号 PICTURE MODEL: BTB60/60E

Marine Tilting Soup Boiling Pan 船用可倾式电汤锅



电动/Motor Driven



手动/Manually Driven

- ◆ 全不锈钢结构
S/S execution
- ◆ 可选择电动倾斜装置和手动转轮式倾斜装置
Handwheel driven tilting device & electric motor driven tilting device are optional
- ◆ 锅体采用三层隔热结构，间接加热，加热高效均匀
The pan body is designed with three insulation tiers, The heating is indirect, efficient and even
- ◆ 带有低水位自动断电保护功能
Automatic water lacking breaker protecting function
- ◆ 设有限位感应装置，锅体倾斜时自动停止加热
Limit switch automatically stops the heating when the pan is tilted
- ◆ 外置压力表、减压阀，对设备进行过压保护
External pressure gauge and pressure releasing valve are applied for overpressure protection
- ◆ 外隔层间填充高复合隔热材料，确保热量不外导
The outer insulation tier is made of compound insulation material and can prevent heat from eradiating
- ◆ 带防风浪气撑锅盖
Anti-storm pan lid is provided
- ◆ 配有长颈摇摆龙头
With a long necked swing faucet

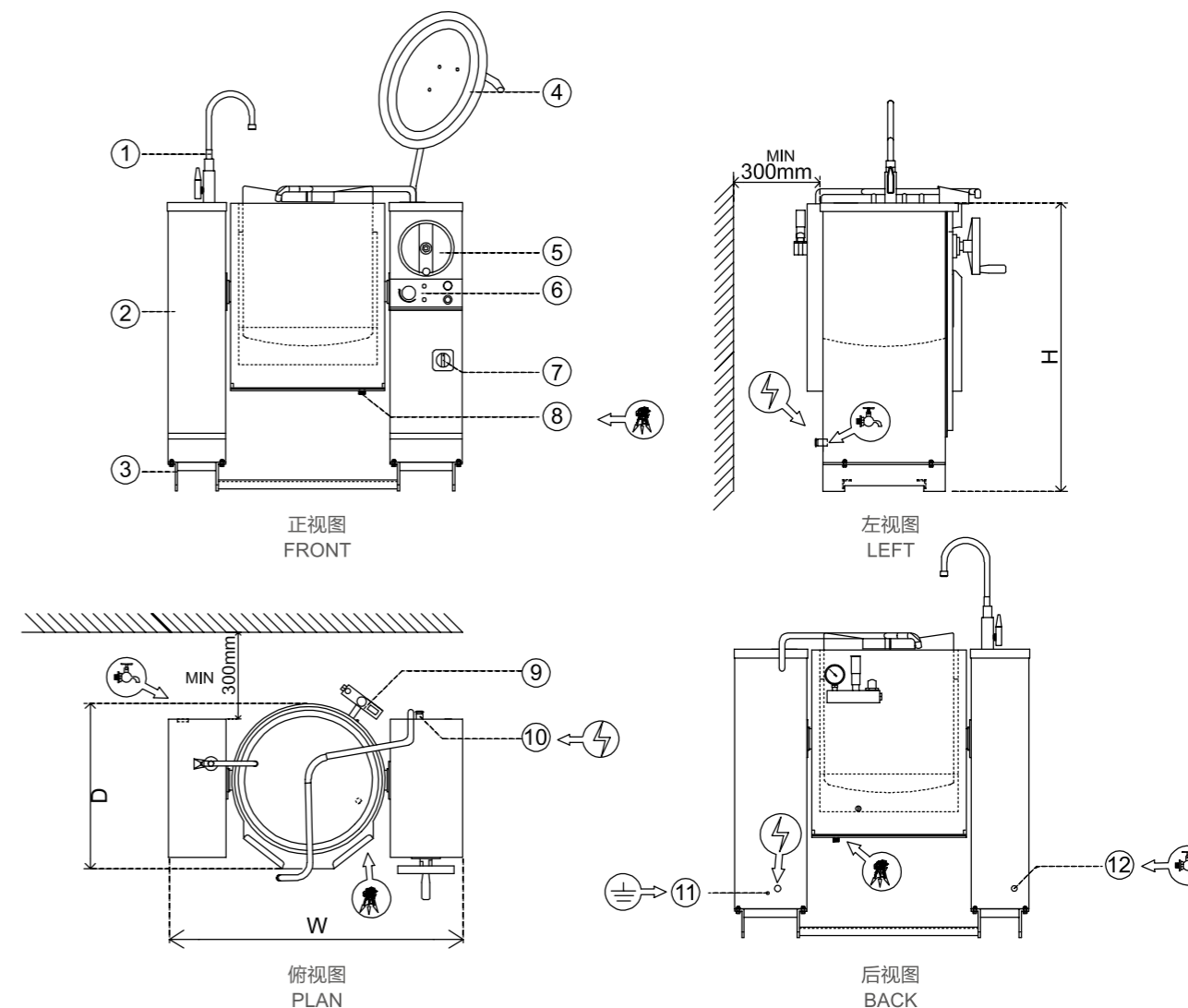

- | | | | |
|----------------------|-------------------------|------------------------------|------------------------|
| ① 加水龙头
Faucet | ④ 汤锅盖
Cover | ⑦ 电源开关
Power Switch | ⑩ 进线填料函
Cable Gland |
| ② 左箱体
Left Column | ⑤ 手动转轮
Handwheel | ⑧ 溢水口
Water Overflow | ⑪ 接地螺栓
Earthing |
| ③ 固定底脚
Fixed Leg | ⑥ 控制面板
Control Panel | ⑨ 安全阀组
Safety Valve Group | ⑫ 进水口
Inlet |

设备名称 Equipment	型号 Model	容量 Capacity	功率 Rating	电制 Voltage	尺寸 Size (W×D×H)	重量 Net Weight
船用可倾式电汤锅 (手动或电动) Marine Tilting Soup Boiling Pan (Manually Driven or Motor Driven)	BTB40/40E	40L	9kW	380-415V/3/50Hz 440-480V/3/60Hz	1020×570×1000mm	130kg
船用可倾式电汤锅 (手动或电动) Marine Tilting Soup Boiling Pan (Manually Driven or Motor Driven)	BTB60/60E	60L	9kW	380-415V/3/50Hz 440-480V/3/60Hz	1020×570×1000mm	135kg
船用可倾式电汤锅 (手动或电动) Marine Tilting Soup Boiling Pan (Manually Driven or Motor Driven)	BTB80/80E	80L	12kW	380-415V/3/50Hz 440-480V/3/60Hz	1120×670×1000mm	152kg
船用可倾式电汤锅 (手动或电动) Marine Tilting Soup Boiling Pan (Manually Driven or Motor Driven)	BTB100/100E	100L	15kW	380-415V/3/50Hz 440-480V/3/60Hz	1120×670×1000mm	166kg